

Driveline Angle Measurement

Special Tool(s)

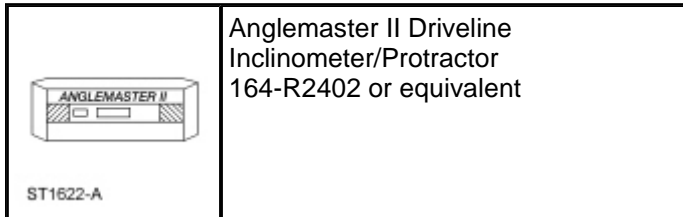

NOTE: This procedure does not apply to CV joints, flex couplers or double cardan joints that are used in some driveshafts. This check is for single-cross and roller-style joints found in the driveshafts.

NOTE: Prior to checking driveline angularity, inspect the U-joints for correct operation.

NOTE: An incorrect driveline angle can cause a vibration or shudder. For additional information, refer to [Section 100-04](#).

NOTE: Driveline angularity is the angular relationship between the engine crankshaft, the driveshaft and the rear axle pinion. Factors determining driveline angularity include ride height, rear spring and engine mounts.

All vehicles

1. Carry out the following preliminary setup steps:
 - Inspect the U-joints for correct operation.
 - Park the vehicle on a level surface such as a drive-on hoist, or back onto a front end alignment rack.
 - Verify the curb position ride height is within specifications with the vehicle unloaded and all of the tires are inflated to their normal operating pressures.
 - Calibrate the Anglemaster II Driveline Inclinometer/Protractor by placing it on a clean, flat level section of the frame rail and press the ALT-ZERO button.

Vehicles with flat-flanged, split-pin or slip-flanged U-joints

2. **NOTE:** If equipped, remove the snap ring to allow access to the base of the U-joint cup. Make sure the Anglemaster II Driveline Inclinometer/Protractor is seated against the U-joint cup.

NOTE: Rotate the driveshaft until the flange U-joint cup is parallel with the floor. This will simplify taking measurements.

To check the U-joint operating angle, install the Anglemaster II Driveline Inclinometer/Protractor. Check and record the flange angle as angle A.

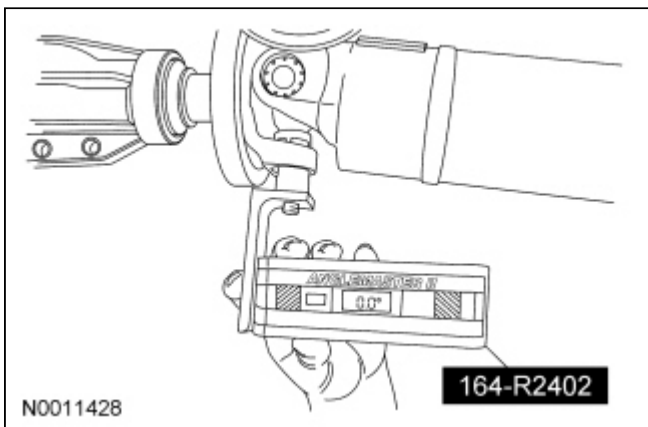
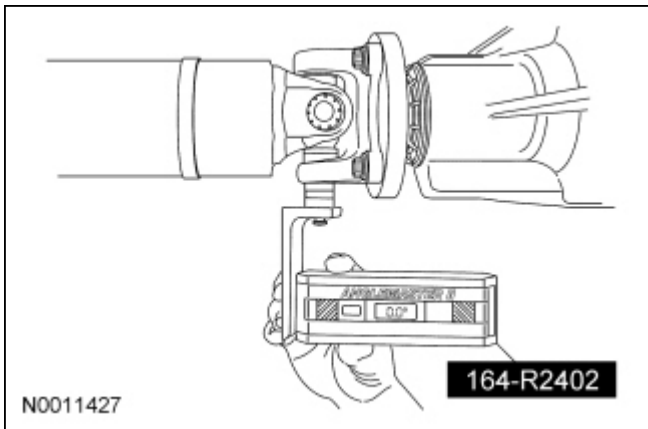

- Using the Anglemaster II Driveline Inclinator/Protractor, measure the slope of the connecting component. Record the measurement of the component angle as angle B.

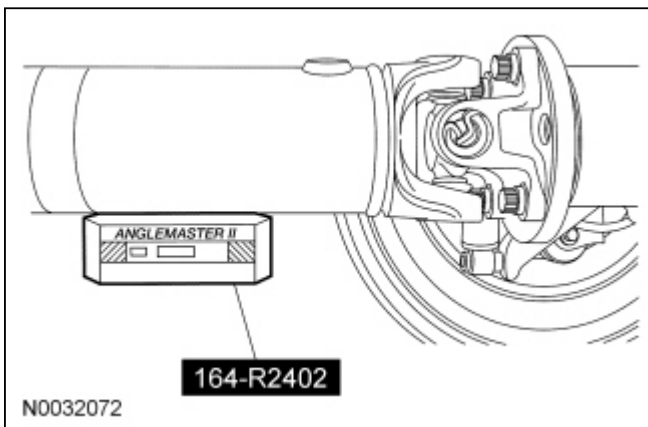

2 piece driveshafts

- NOTE:** Repeat this step for each center support bearing on the driveshaft.

NOTE: It is not necessary to remove the U-joint snap ring, if equipped, for these measurements.

Using the Anglemaster II Driveline Inclinator/Protractor, measure the slope of the components in front and behind the center support bearing U-joint in the area indicated. Record the front component as angle A and the rear component as angle B.

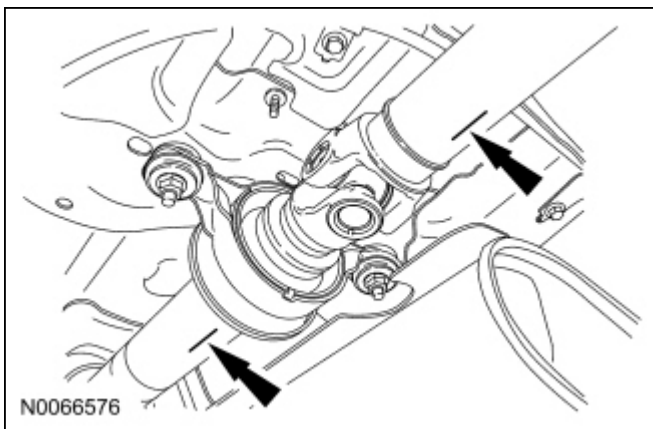

All vehicles

5. **NOTE:** When 2 connected components slope in the same direction, subtract the smallest number from the larger number to find the U-joint operating angle. When 2 connected components slope in the opposite direction, add the measurements to find the U-joint operating angle.

Calculate the difference in the slope of the components to determine the U-joint operating angle.

- The U-joint operating angle is the angle formed by 2 yokes connected by a cross and bearing kit. Ideally, the operating angles on each connection of the driveshaft must:
 - be equal or within one degree of each other.
 - have a 3 degree maximum operating angle.
 - have at least one-half of one degree continuous operating angle.

6. If the angle is not within specifications, repair or adjust to obtain the correct angle. Inspect the engine mounts, transmission mounts, center support bearing mounting, rear suspension, rear axle, rear axle mounting or the frame for wear or damage.

2 piece driveshaft

7. **NOTE:** When 2 connected components slope in the same direction, subtract the smallest number from the larger number to find the U-joint operating angle. When 2 connected components slope in the opposite direction, add the measurements to find the U-joint operating angle.

Calculate the difference in the slope of the components to determine the U-joint operating angle.

- The U-joint operating angle is the angle formed by 2 yokes connected by a cross and bearing kit. Ideally, the operating angles on each connection of the driveshaft must:
 - be equal or within one degree of each other.
 - have a 2 degree front u-joint angle.
 - have at least one-half of one degree continuous operating angle.

8. If the angle is not within specifications, repair or adjust to obtain the correct angle. Inspect the engine mounts, transmission mounts, center support bearing mounting, rear suspension, rear axle, rear axle mounting or the frame for wear or damage.
- If the front u-joint operating angle is less than 1.9 degrees or higher than 2.5 degrees do not adjust the center support bearing. For additional information, refer to [Section 100-04](#).

